

ANNALES
HENRI LEBESGUE

JOHN A. BALDWIN

STEVEN SIVEK

INSTANTON L -SPACES AND SPLICING

L -ESPACES INSTANTONNIQUES ET
RECOLLEMENT D'EXTÉRIEURS DE NŒUDS

ABSTRACT. — We prove that the 3-manifold obtained by gluing the complements of two nontrivial knots in homology 3-sphere instanton L -spaces, by a map which identifies meridians with Seifert longitudes, cannot be an instanton L -space. This recovers the recent theorem of Lidman–Pinzón–Caicedo–Zentner that the fundamental group of every closed, oriented, toroidal 3-manifold admits a nontrivial $SU(2)$ -representation, and consequently Zentner’s earlier result that the fundamental group of every closed, oriented 3-manifold besides the 3-sphere admits a nontrivial $SL(2, \mathbb{C})$ -representation.

RÉSUMÉ. — Nous prouvons que la variété de dimension 3 obtenue en recollant les complémentaires de deux nœuds non triviaux dans des L -espaces instantoniques qui sont des sphères d’homologie, par une application qui identifie les méridiens avec les longitudes de Seifert, ne peut pas être un L -espace instantonique. Cela redémontre le théorème récent de Lidman–Pinzón–Caicedo–Zentner selon lequel le groupe fondamental de toute variété fermée orientée toroïdale de dimension 3 admet une $SU(2)$ -représentation non triviale, et par conséquent le résultat précédent de Zentner que le groupe fondamental de toute variété de dimension 3 fermée orientée différente de la sphère admet une représentation non triviale dans $SL(2, \mathbb{C})$.

Keywords: Instanton Floer homology, L -spaces, incompressible tori.

2020 Mathematics Subject Classification: 57R58, 57K31.

DOI: <https://doi.org/10.5802/ahl.148>

(*) JAB was supported by NSF FRG Grant DMS-1952707 and NSF CAREER Grant DMS-1454865.

1. Introduction

A productive way to study 3-manifolds is to study homomorphisms from their fundamental groups to simple non-abelian groups like $SU(2)$. This strategy was used by Kronheimer and Mrowka in their celebrated proof of the Property P Conjecture [KM04]. More precisely, they proved that if $K \subset S^3$ is a nontrivial knot, then there is a nontrivial homomorphism

$$\pi_1(S_1^3(K)) \rightarrow SU(2),$$

certifying that the surgered manifold is not a homotopy sphere. It is natural to conjecture more generally that *every* homology 3-sphere $Y \not\cong S^3$ admits a nontrivial homomorphism

$$\pi_1(Y) \rightarrow SU(2).$$

This is a generalization of the Poincaré Conjecture, and is listed as [Kirby97, Problem 3.105 (A)] on Kirby’s famous problem list. Lidman, Pinzón-Caicedo, and Zentner recently proved this conjecture for toroidal homology 3-spheres [LPCZ21], recovering in the process Zentner’s beautiful result [Zen18] that the conjecture holds with $SL(2, \mathbb{C})$ in place of $SU(2)$.

In this article, we take inspiration from Heegaard–Floer homology to prove a result in the instanton Floer setting, which we then use to give different and simpler proofs of the main results of [LPCZ21, Zen18], as described below.

An *instanton L -space* is a rational homology 3-sphere Y whose framed instanton homology [KM11b, Sca15] has the smallest dimension possible over \mathbb{Q} :

$$\dim I^\#(Y) = |H_1(Y; \mathbb{Z})|.$$

The topological significance of this notion is that if Y is an *integer* homology 3-sphere, then Y is *not* an instanton L -space if and only if the reduced instanton homology $\hat{I}(Y)$ is nonzero [Sca15, Theorem 1.3], in which case there exists a nontrivial homomorphism

$$\pi_1(Y) \rightarrow SU(2).$$

(See also [BS18, Theorem 4.2].) Our main theorem is the following:

THEOREM 1.1. — *Let C be the splice of nontrivial knots $\alpha \subset A$ and $\beta \subset B$ in homology sphere instanton L -spaces, formed by gluing their complements by a map that identifies meridians with Seifert longitudes. Then*

$$\dim I^\#(C) \geq 1 + 4 \cdot \dim KHI(A, \alpha, g(\alpha)) \cdot \dim KHI(B, \beta, g(\beta)) \geq 5.$$

In particular, the homology sphere C is not an instanton L -space.

Here, *KHI* refers to a version of Floer’s *instanton knot homology*, defined in [KM10, § 7.6]. This theory was a key tool, for instance, in Kronheimer and Mrowka’s proof that Khovanov homology detects the unknot [KM11a], and is conjectured to be isomorphic to a version of Heegaard knot Floer homology (as mentioned below).

A Heegaard–Floer analogue of Theorem 1.1, with coefficients in $\mathbb{Z}/2\mathbb{Z}$ rather than \mathbb{Q} , was first established by Hedden and Levine in [HL16], and later generalized by Eftekhary [Eft15, Eft20] and then by Hanselman, Rasmussen, and Watson [HRW17]. Their approaches all used bordered Heegaard Floer homology or something similar.

By contrast, our proof of Theorem 1.1 is largely “theory-independent,” meaning that it can be readily adapted to give alternative proofs of the corresponding results in Heegaard–Floer and monopole Floer homology as well. Indeed, the only tools it requires to prove these results over a field \mathbb{F} are a surgery exact triangle with \mathbb{F} coefficients, a suitable excision theorem, and an adjunction inequality. We remark that the Heegaard–Floer version over a field of characteristic zero would also follow from Theorem 1.1 together with the conjectural isomorphisms

$$I^\#(Y; \mathbb{Q}) \cong \widehat{HF}(Y; \mathbb{Q}) \quad \text{and} \quad KHI(Y, K, g(K); \mathbb{Q}) \cong \widehat{HFK}(Y, K, g(K); \mathbb{Q}),$$

which are special cases of [KM10, Conjecture 7.24].

The advantage of proving a result like Theorem 1.1 in the instanton Floer setting has to do, of course, with the connection between framed instanton homology and the fundamental group, highlighted above. In particular, Theorem 1.1 has as a corollary the following result of Lidman, Pinzón-Caicedo, and Zentner, alluded to at the beginning. Their proof used a different version of instanton Floer homology, together with arguments involving exact triangles, cabling, the pillowcase, and holonomy perturbations.

COROLLARY 1.2 ([LPCZ21]). — *There exists a nontrivial homomorphism $\pi_1(Y) \rightarrow SU(2)$ for every closed, oriented, toroidal 3-manifold Y .*

Corollary 1.2, in turn, recovers the result of Zentner below, whose original proof involved extensive analysis of the pillowcase, holonomy perturbations, and degree-1 maps.

COROLLARY 1.3 ([Zen18]). — *There exists a nontrivial homomorphism $\pi_1(Y) \rightarrow SL(2, \mathbb{C})$ for every closed, oriented 3-manifold $Y \not\cong S^3$.*

We remark that Hanselman, Rasmussen, and Watson proved [HRW17] something more general than Theorem 1.1 in the Heegaard–Floer setting. In particular, they showed that the Heegaard–Floer homology of *any* toroidal manifold (not necessarily coming from a splice of knots in homology sphere L -spaces) has dimension at least five (over $\mathbb{Z}/2\mathbb{Z}$). We conjecture that the analogous statement holds for framed instanton homology:

CONJECTURE 1.4. — *If Y is a closed, oriented, toroidal rational homology 3-sphere, then $\dim I^\#(Y) \geq 5$.*

Moreover, toroidal manifolds which achieve the bound of five in Heegaard–Floer homology are classified in [HRW17]—they are certain splices of trefoils. It would be interesting to try and prove that framed instanton homology is 5-dimensional as well for these trefoil splices.

If Conjecture 1.4 holds, then a toroidal rational homology sphere Y with $|H_1(Y)| < 5$ is not an instanton L -space. This would imply the following, by [BS18, Corollary 4.10]:

CONJECTURE 1.5. — *There exists an irreducible homomorphism $\pi_1(Y) \rightarrow SU(2)$ for every toroidal rational homology 3-sphere Y with $|H_1(Y)| < 5$.*

Combined with the classification of $SU(2)$ -abelian Seifert fibered 3-manifolds in [SZ22, Theorem 1.1], and the fact that fundamental groups of hyperbolic 3-manifolds always admit irreducible $SL(2, \mathbb{C})$ -representations, a proof of Conjecture 1.5 would be enough to classify rational homology 3-spheres Y with $|H_1(Y)| < 5$ which admit irreducible homomorphisms

$$\pi_1(Y) \rightarrow SL(2, \mathbb{C}),$$

extending Zentner's result for homology 3-spheres stated in Corollary 1.3.

We prove Theorem 1.1 and its two corollaries in §3, after a review of framed instanton homology in § 2. The proof of Theorem 1.1 relies on Theorem 3.1, which we prove in § 4 and may be of independent interest.

Acknowledgements

We thank Josh Greene, Matt Hedden, Adam Levine, and Tye Lidman for helpful conversations in the course of this work, and to the anonymous referees, whose feedback helped improve this paper. Thanks also go to Tye Lidman, Juanita Pinzón-Caicedo, and Raphael Zentner for their lovely paper [LPCZ21], which inspired this project.

2. Background

The following is a brief review of framed instanton homology, limited to the background needed to follow the flow of our arguments. Instanton homology can be defined over \mathbb{Z} , but we will work with coefficients in \mathbb{Q} throughout. For more details, see [KM10, § 7].

Let Y be a closed, oriented 3-manifold, and $\lambda \subset Y$ a multicurve in Y which is *admissible*, meaning that it intersects some closed surface of positive genus in an odd number of points. One can associate to this data an *admissible* $SO(3)$ -bundle over Y with second Stiefel–Whitney class Poincaré dual to λ , and then define a corresponding instanton Floer homology group $I_*(Y)_\lambda$.

Suppose $\Sigma \subset Y$ is a closed, oriented surface of genus $g > 0$, and $\text{pt} \in Y$ is a point. These submanifolds induce commuting linear operators $\mu(\Sigma), \mu(\text{pt})$ on $I_*(Y)_\lambda$ whose simultaneous eigenvalues are contained in the set

$$\{(i^r \cdot 2k, (-1)^r \cdot 2)\},$$

for $0 \leq r \leq 3$ and $0 \leq k \leq g-1$. We let

$$I_*(Y|\Sigma)_\lambda \subset I_*(Y)_\lambda$$

denote the (generalized) simultaneous $(2g-2, 2)$ -eigenspace of these operators. These groups depend only on the homology classes of Σ and λ in $H_2(Y; \mathbb{Z})$ and $H_1(Y; \mathbb{Z}/2\mathbb{Z})$, respectively.

Now let Y be any closed, oriented 3-manifold, and $\lambda \subset Y$ *any* multicurve. The framed instanton homology of (Y, λ) is defined by

$$I^\#(Y, \lambda) := I_*\left(Y \# T^3\right)_{\lambda \cup \lambda_T},$$

where λ_T is a circle fiber in T^3 (note that $\lambda \cup \lambda_T$ is automatically admissible in $Y \# T^3$). We will use the notation $I^\#(Y)$ or $I^\#(Y, 0)$ for $I^\#(Y, \lambda)$ when λ is nullhomologous mod 2. Given a closed, oriented surface $\Sigma \subset Y$ of genus $g > 0$, we define

$$I^\#(Y, \lambda|\Sigma) := I_* \left(Y \# T^3 \Big|_{\Sigma} \right)_{\lambda \cup \lambda_T}.$$

By [BS22b, Lemma 2.5], we have the symmetry

$$(2.1) \quad I^\#(Y, \lambda|\Sigma) \cong I^\#(Y, \lambda|-\Sigma)$$

relating the generalized $(2g-2)$ and $(2-2g)$ -eigenspaces of $\mu(\Sigma)$ acting on $I^\#(Y, \lambda)$.⁽¹⁾ When $g \geq 2$, these *extremal* eigenspaces are disjoint, and we define

$$I^\#(Y, \lambda)_\Sigma := I^\#(Y, \lambda|\Sigma) \oplus I^\#(Y, \lambda|-\Sigma).$$

Floer’s surgery exact triangle [Flo90] associates to a framed knot $K \subset Y$ an exact triangle

$$\cdots \rightarrow I_*(Y)_\lambda \rightarrow I_*(Y_0(K))_{\lambda \cup \mu} \rightarrow I_*(Y_1(K))_\lambda \rightarrow \cdots,$$

where μ is the image in $Y_0(K)$ of a meridian of K , provided that all three multicurves are admissible. As discussed in [Sca15, § 7.5], this gives rise to a surgery exact triangle in framed instanton homology as well, which takes the form

$$\cdots \rightarrow I^\#(Y, \lambda) \rightarrow I^\#(Y_0(K), \lambda \cup \mu) \rightarrow I^\#(Y_1(K), \lambda) \rightarrow \cdots$$

for any multicurves λ and μ . We can always arrange, via a judicious choice of λ , that these multicurves are nullhomologous mod 2 in their respective manifolds, as in [BS21, § 2.2], and so obtain an exact triangle of the form

$$\cdots \rightarrow I^\#(Y) \rightarrow I^\#(Y_0(K)) \rightarrow I^\#(Y_1(K)) \rightarrow \cdots$$

The maps in these exact triangles are induced by the associated trace cobordisms, equipped with $SO(3)$ -bundles whose second Stiefel–Whitney classes are Poincaré dual to certain surface cobordisms between the corresponding multicurves; see [ABDS20, § 2.3].

3. The proofs

Before proving Theorem 1.1, we introduce some notation and preliminary results. One of these is the theorem below, whose proof we defer to § 4.

THEOREM 3.1. — *Let S be a splice of nontrivial knots $\alpha \subset A$ and $\beta \subset B$ in homology spheres, formed by gluing their complements by a map that identifies the Seifert longitudes. Then*

$$\dim I^\#(S, \lambda)_\Sigma = 4 \cdot \dim KHI(A, \alpha, g(\alpha)) \cdot \dim KHI(B, \beta, g(\beta)) \geq 4$$

for all λ , where $\Sigma \subset S$ is the union of minimal genus Seifert surfaces for α and β .

⁽¹⁾Indeed, $I^\#(Y, \lambda|-\Sigma)$ is the $(2-2g, 2)$ -eigenspace of $\mu(\Sigma), \mu(\text{pt})$ since $\mu(-\Sigma) = -\mu(\Sigma)$.

As remarked in the introduction, $KHI(A, \alpha)$ (and similarly $KHI(B, \beta)$) refers to the instanton knot homology studied by Kronheimer and Mrowka [KM10, § 7.6], defined as the sutured instanton homology of the complement $A \setminus N(\alpha)$ with sutures a pair of oppositely oriented meridians. It admits an “Alexander decomposition” into summands indexed by integers i with $|i| \leq g(\alpha)$; the top summand $KHI(A, \alpha, g(\alpha))$ is nonzero, and it arises as the sutured instanton homology of the complement of a genus- $g(\alpha)$ Seifert surface.

The strategy behind our proof of Theorem 1.1 will involve relating the splice C to a splice S of the form described in the theorem above, via surgery. We will then use surgery exact triangles to show that the extremal subspace $I^\#(S, \lambda)_\Sigma$ “persists” and contributes at least four to the dimension of $I^\#(C)$.

Suppose $\alpha \subset A$ is a knot in a homology sphere instanton L -space. Since $\dim I^\#(A) = 1$, the surgery exact triangle

$$\cdots \rightarrow I^\#(A) \rightarrow I^\#(A_i(\alpha)) \rightarrow I^\#(A_{i+1}(\alpha)) \rightarrow \cdots$$

implies that

$$\dim I^\#(A_{i+1}(\alpha)) = \dim I^\#(A_i(\alpha)) \pm 1$$

for each integer i . In [BS21, § 3] (see also [BS22a, Remark 6.3]), we proved that the sequence

$$\left\{ \dim I^\#(A_i(\alpha)) \right\}_{i \in \mathbb{Z}}$$

either has one local minimum; or else it has two local minima at $i = \pm 1$, satisfying

$$\dim I^\#(A_{-1}(\alpha)) = \dim I^\#(A_1(\alpha)).^{(2)}$$

In the first case, we define $\nu^\#(\alpha)$ to be the unique i at which the local minimum is achieved; in the second, we define $\nu^\#(\alpha) = 0$. Note that $\nu^\#(\alpha)$ changes sign upon reversing the orientation of A . The following is a combination of [BS22a, Theorem 6.1] and [BS21, Proposition 3.3]:

PROPOSITION 3.2. — *If $\nu^\#(\alpha) = 0$ then for some λ ,*

$$\dim I^\#(A_0(\alpha), \lambda) - 1 = \dim I^\#(A_{-1}(\alpha)) = \dim I^\#(A_1(\alpha)).$$

If $\nu^\#(\alpha) \neq 0$ then $\dim I^\#(A_0(\alpha), \lambda)$ is independent of λ .

The upshot of this discussion is the lemma below. It follows immediately from Proposition 3.2, and will be used shortly in the proof of Theorem 1.1:

LEMMA 3.3. — *Consider the surgery exact triangles:*

$$\begin{aligned} \cdots \rightarrow I^\#(A) \xrightarrow{F_{-1}} I^\#(A_{-1}(\alpha)) \xrightarrow{G_0} I^\#(A_0(\alpha), \lambda) \rightarrow \cdots \\ \cdots \rightarrow I^\#(A) \xrightarrow{F_0} I^\#(A_0(\alpha), \lambda) \xrightarrow{G_1} I^\#(A_1(\alpha)) \rightarrow \cdots \end{aligned}$$

The following hold:

- *If $\nu^\#(\alpha) = 0$, then for some λ , both G_0 and F_0 are injective.*
- *If $\nu^\#(\alpha) > 0$, then for any λ , both F_0 and F_{-1} are injective.*

⁽²⁾We proved this for knots in the 3-sphere, but the only fact about S^3 we used is that $\dim I^\#(S^3) = 1$. This is why we require A and B to be homology sphere instanton L -spaces: otherwise we cannot guarantee that the sequences $\{\dim I^\#(A_i(\alpha))\}_{i \in \mathbb{Z}}$ and $\{\dim I^\#(B_i(\beta))\}_{i \in \mathbb{Z}}$ behave as described.

- If $\nu^\sharp(\alpha) < 0$, then for any λ , both G_0 and G_1 are injective. □

Proof of Theorem 1.1. — Let $\alpha \subset A$ and $\beta \subset B$ be as in the hypothesis of the theorem. Then C is the homology sphere formed by gluing the knot complements

$$C = (A - N(\alpha)) \cup (B - N(\beta)),$$

via an orientation-reversing homeomorphism of their boundaries which identifies meridians with Seifert longitudes. Note that the theorem is insensitive to the overall orientation of C , so by possibly reversing the orientations of A and B we can (and will) assume that either:

$$(3.1) \quad \nu^\sharp(\alpha) \leq 0 \quad \text{and} \quad \nu^\sharp(\beta) \leq 0,$$

or

$$(3.2) \quad \nu^\sharp(\alpha) < 0 \quad \text{and} \quad \nu^\sharp(\beta) > 0.$$

We will henceforth use the shorthand

$$A_i = A_i(\alpha) \text{ and } B_i = B_i(\beta)$$

for surgeries on these knots. Let Σ_α and Σ_β be minimal genus Seifert surfaces for α and β , and let $\hat{\alpha}$ and $\hat{\beta}$ be pushoffs of these knots in Σ_α and Σ_β .

Let $\gamma \subset C$ be a curve on the splicing torus of slope -1 with respect to the usual coordinate system inherited from $A - N(\alpha)$. Note that 0-surgery on γ with respect to its torus framing yields the connected sum

$$(3.3) \quad C_0(\gamma) \cong A_{-1} \# B_{-1}.$$

Performing 1-surgery on γ amounts to changing the gluing map by a Dehn twist, and yields another splice

$$S := C_1(\gamma)$$

of the form described in Theorem 3.1, in which the Seifert longitudes of α and β are identified. See Figure 3.1 for a schematic of these surgeries. Let

$$\Sigma := \Sigma_\alpha \cup \Sigma_\beta \subset S$$

be the closed surface of genus at least two obtained as the union of the Seifert surfaces Σ_α and Σ_β along their boundaries.

Remark 3.4. — We have seen that C is related to both $A_{-1} \# B_{-1}$ and S via surgery. We have some understanding of the framed instanton homology of the latter two manifolds thanks to Lemma 3.3 and Theorem 3.1. As mentioned earlier, our strategy in proving Theorem 1.1 will be to use surgery exact triangles involving these manifolds, and other surgeries in which Σ is compressed, to show that the extremal eigenspaces of the framed instanton homology of S with respect to Σ contribute at least four to the dimension of $I^\sharp(C)$.

We note that C can be described, dually, as +1-surgery on the connected sum

$$\hat{\alpha} \# \hat{\beta} \subset A_{-1} \# B_{-1},$$

as shown on the left in Figure 3.2; see [Sav02, § 1.1.7] or [KLT21, Lemma 2.1]. This perspective will be helpful in understanding the commutative diagrams that follow.

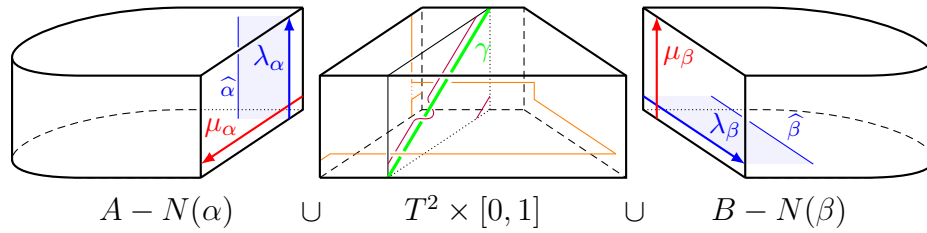

Figure 3.1. Performing 0-surgery on $\gamma \subset C$ with respect to its T^2 framing compresses the torus to a sphere and produces $A_{-1}\#B_{-1}$, because γ is isotopic to a peripheral curve of slope -1 in each knot exterior. Doing $+1$ -surgery instead produces a splicing in which λ_α and λ_β are glued together, because the orange curve is isotopic to the purple curve and thus bounds a disk.

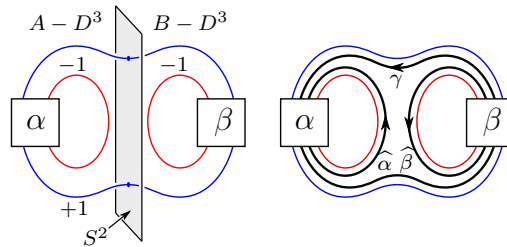

Figure 3.2. Left, a surgery description of C . We will hereafter indicate -1 , $+1$, and 0 -surgeries using the colors red, blue, and green, respectively. Right, the curves $\hat{\alpha}$, $\hat{\beta}$, and γ in C shown in black.

The framed instanton homologies of C , $C_0(\gamma)$, and $C_1(\gamma)$ fit into a surgery exact triangle, a portion of which is shown in the top row of the commutative diagram below:

$$(3.4) \quad \begin{array}{ccccc} I^\#(C) & \longrightarrow & I^\#(A_{-1}\#B_{-1}) & \xrightarrow{e} & I^\#(S, \lambda_C) \\ \downarrow & & \downarrow f & & \downarrow d \\ I^\#(A_0\#B, \lambda_A) & \xrightarrow{h} & I^\#(A_0\#B_{-1}, \lambda_A) & \xrightarrow{g} & I^\#(A_0\#B_0, \lambda_A \cup \lambda_B), \end{array}$$

depicted in terms of surgery diagrams in Figure 3.3.

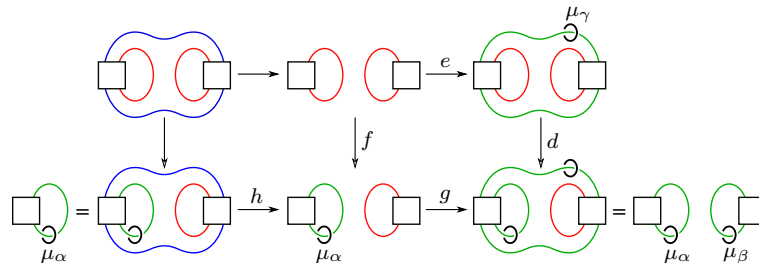

Figure 3.3. Surgery descriptions of the manifolds in the commutative diagram (3.4), and pictures of the meridians μ_α , μ_β , and μ_γ . We will no longer label the boxes, but will imagine that they contain α and β as in Figure 3.2.

The vertical maps in the diagram (3.4) are induced by the trace of 0-surgery on $\widehat{\alpha}$. Here, $\lambda_A, \lambda_B, \lambda_C$ are mod 2 multiples

$$\begin{aligned} \lambda_A &= n_\alpha \mu_\alpha \\ \lambda_B &= n_\beta \mu_\beta \\ \lambda_C &= n_\gamma \mu_\gamma \end{aligned}$$

of the meridians $\mu_\alpha, \mu_\beta, \mu_\gamma$ of α, β, γ , respectively, subject to the mod 2 condition

$$n_\alpha + n_\beta + n_\gamma = 0.$$

Moreover, by the Künneth formula for $I^\#$ of connected sums, and its naturality with respect to maps induced by split cobordisms [Sca15, § 7], if we let a, b, c denote the cobordism maps in the surgery exact triangles

$$\begin{aligned} \cdots \rightarrow I^\#(A) \rightarrow I^\#(A_{-1}) \xrightarrow{a} I^\#(A_0, \lambda_A) \rightarrow \cdots \\ \cdots \rightarrow I^\#(B) \xrightarrow{c} I^\#(B_{-1}) \xrightarrow{b} I^\#(B_0, \lambda_B) \rightarrow \cdots, \end{aligned}$$

then we can think of f, g, h as

$$\begin{aligned} f &= a \otimes \text{id} \\ g &= \text{id} \otimes b \\ h &= \text{id} \otimes c. \end{aligned}$$

This setup in place, we now prove Theorem 1.1, taking the cases (3.1) and (3.2) in turn.

First, assume we are in case (3.1), so that

$$\nu^\#(\alpha) \leq 0 \quad \text{and} \quad \nu^\#(\beta) \leq 0.$$

Then Lemma 3.3 implies that for some choice of λ_A and λ_B , both a and b , and therefore f and g , are injective. It then follows from the commutativity of the diagram (3.4) that d is injective on the image of e . On the other hand,

$$(3.5) \quad I^\#(S, \lambda_C)_\Sigma \subset \ker d$$

since d is induced by 0-surgery on $\widehat{\alpha} \subset S$, which compresses Σ , and thus Σ is homologous in the associated 2-handle cobordism to a surface of strictly smaller genus. Therefore,

$$\text{Im } e \cap I^\#(S, \lambda_C)_\Sigma = 0.$$

Since $\dim I^\#(C) \geq \dim \text{coker}(e)$, we have

$$\dim I^\#(C) \geq \dim I^\#(S, \lambda_C)_\Sigma = 4 \cdot \dim KHI(A, \alpha, g(\alpha)) \cdot \dim KHI(B, \beta, g(\beta)) \geq 4,$$

by Theorem 3.1. Moreover, the leftmost inequality is strict since $\dim I^\#(C)$ has the same parity as $\chi(I^\#(C)) = 1$, proving the theorem in this case.

Next, assume we are in case (3.2), so that

$$\nu^\#(\alpha) < 0 \quad \text{and} \quad \nu^\#(\beta) > 0.$$

By Lemma 3.3, this implies that a and c , and therefore f and h , are injective for any choice of λ_A and λ_B . This case will occupy the rest of the proof. Let us henceforth take

$$\lambda_A = \lambda_B = \lambda_C = 0.$$

The commutative diagram (3.4) then becomes:

$$(3.6) \quad \begin{array}{ccccc} I^\#(C) & \longrightarrow & I^\#(A_{-1}\#B_{-1}) & \xrightarrow{e} & I^\#(S) \\ \downarrow & & \downarrow f & & \downarrow d \\ I^\#(A_0\#B) & \xhookrightarrow{h} & I^\#(A_0\#B_{-1}) & \xrightarrow{g} & I^\#(A_0\#B_0). \end{array}$$

Our goal will be to once again show that

$$\text{Im } e \cap I^\#(S)_\Sigma = 0,$$

from which the theorem will follow as before. Suppose, for a contradiction, that this intersection contains a nonzero element $e(x)$ for some

$$x \in I^\#(A_{-1}\#B_{-1}).$$

Then $f(x)$ is nonzero since f is injective. Note by commutativity and (3.5) that

$$g(f(x)) = d(e(x)) = 0.$$

Exactness of the bottom row of (3.6) then implies that $f(x) = h(y)$ for some nonzero

$$y \in I^\#(A_0\#B).$$

The maps f and h also fit into the following diagram in which the rows are portions of surgery exact triangles, and the vertical maps are induced by the trace of -1 -surgery on $\tilde{\beta}$:

$$(3.7) \quad \begin{array}{ccccc} I^\#(A_{-1}\#B) & \xhookrightarrow{i} & I^\#(A_0\#B) & \xrightarrow{k} & I^\#(A\#B) \\ \downarrow j & & \downarrow h & & \downarrow l \\ I^\#(A_{-1}\#B_{-1}) & \xhookrightarrow{f} & I^\#(A_0\#B_{-1}) & \xrightarrow{m} & I^\#(A\#B_{-1}). \end{array}$$

We claim that x is in the image of j . Note that j and l can be viewed as maps of the form $\text{id} \otimes c$ and are thus injective. A similar argument shows that i is injective given that a is. Commutativity and the exactness of the bottom row of this diagram implies that

$$l(k(y)) = m(h(y)) = m(f(x)) = 0.$$

Then $k(y) = 0$ since l is injective. Exactness of the top row then implies that $y = i(w)$ for some nonzero

$$w \in I^\#(A_{-1}\#B).$$

Then

$$f(j(w)) = h(i(w)) = h(y) = f(x),$$

which implies that $j(w) = x$, as claimed, since f is injective.

The map j from (3.7) also fits into the following commutative diagram with e from (3.6):

$$(3.8) \quad \begin{array}{ccccc} & & & & I^\#(A_0 \# B_0) \\ & & & & \downarrow p \\ I^\#(C_{+1}) & \longrightarrow & I^\#(A_{-1} \# B) & \xrightarrow{n} & I^\#(S_{+1}) \\ \downarrow & & \downarrow j & & \downarrow o \\ I^\#(C) & \longrightarrow & I^\#(A_{-1} \# B_{-1}) & \xrightarrow{e} & I^\#(S) \end{array}$$

in which the lower vertical maps are induced by the trace of -1 -surgery on $\widehat{\beta}$; the middle row is a portion of the surgery exact triangle associated to 0 and 1 -surgery on a copy of γ on the splicing torus in C_{+1} with respect to its torus framing; and the rightmost column is part of the surgery triangle associated to -1 and 0 -surgery on $\widehat{\beta} \subset S_{+1}$, as in Figure 3.4.

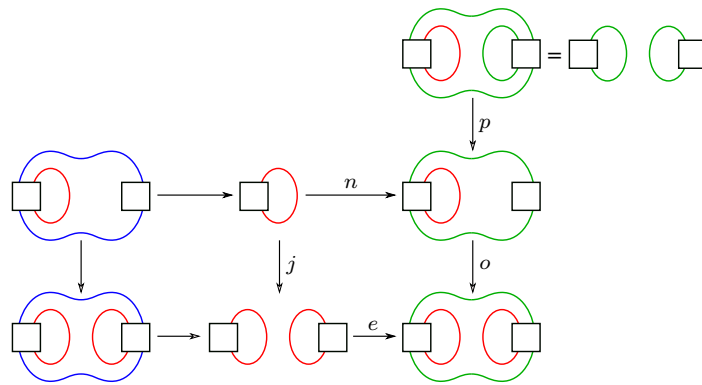

Figure 3.4. Surgery descriptions of the manifolds in the diagram (3.8).

We can write

$$n(w) = z + r,$$

where

$$z \in I^\#(S_{+1})_\Sigma$$

is a linear combination of elements in the extremal eigenspaces of $\mu(\Sigma)$ acting on $I^\#(S_{+1})$, and r is a linear combination of elements in the other eigenspaces. By commutativity,

$$o(z) + o(r) = o(n(w)) = e(j(w)) = e(x) \in I^\#(S)_\Sigma.$$

Since the map o respects the eigenspaces of $\mu(\Sigma)$, it follows in exactly the same way as (3.5) that $o(r) = 0$, which implies by exactness that $r = p(s)$ for some

$$s \in I^\#(A_0 \# B_0).$$

To complete the proof, we study the element $u(r)$ in the following diagram involving n :

$$(3.9) \quad \begin{array}{ccccc} & & & & I^\#(A_0 \# B_0) \\ & & & & \downarrow p \\ & & & & I^\#(S_{+1}) \\ I^\#(C_{+1}) & \longrightarrow & I^\#(A_{-1} \# B) & \xrightarrow{n} & I^\#(S_{+1}) \\ \downarrow & & \downarrow q & & \downarrow u \\ I^\#(A_0 \# B_{+1}, \mu_\alpha) & \longrightarrow & I^\#(A_0 \# B, \mu_\alpha) & \xrightarrow{v} & I^\#(A_0 \# B_0, \mu_\alpha \cup \mu_\beta), \end{array}$$

in which the rows are portions of surgery exact triangles corresponding to 0- and 1-surgery on copies of γ . In the manifolds on the bottom row, this copy of γ is isotopic to β , so this row can be viewed as the exact triangle corresponding to 0- and 1-surgery on β , as indicated in Figure 3.5. The lower vertical maps are induced by the trace of 0-surgery on $\hat{\alpha}$.

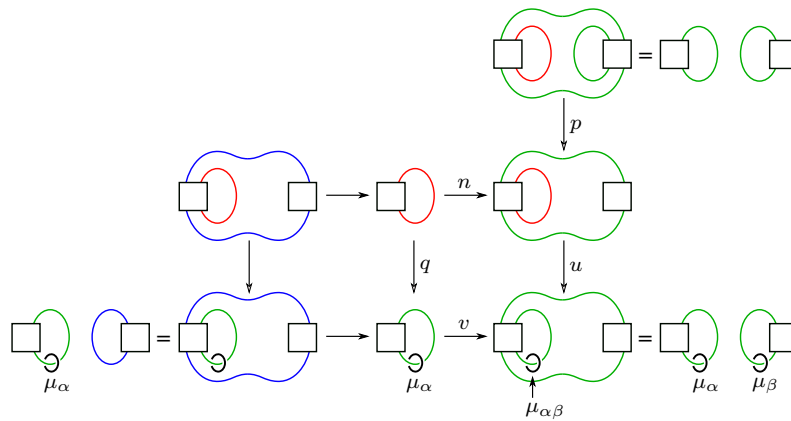

Figure 3.5. Surgery descriptions of the manifolds in the diagram (3.9).

The map q is of the form $a' \otimes \text{id}$, where a' is the map in the surgery exact triangle

$$\dots \rightarrow I^\#(A) \rightarrow I^\#(A_{-1}) \xrightarrow{a'} I^\#(A_0, \mu_\alpha) \rightarrow \dots$$

Since $\nu^\#(\alpha) < 0$, Lemma 3.3 implies that a' , and therefore q , is injective. Similarly, we can view v as a map of the form $\text{id} \otimes t$, where t is the map in the surgery exact triangle

$$\dots \rightarrow I^\#(B) \xrightarrow{t} I^\#(B_0, \mu_\beta) \rightarrow I^\#(B_1) \rightarrow \dots$$

Since $\nu^\#(\beta) > 0$, Lemma 3.3 implies that t , and hence v , is injective. It follows that $v(q(w))$ is nonzero. By commutativity of (3.9),

$$v(q(w)) = u(n(w)) = u(z) + u(r).$$

Note that $u(z) = 0$ by the same argument as in (3.5): namely, that u respects the eigenspaces of $\mu(\Sigma)$, we have

$$z \in I^\#(S_{+1})_\Sigma,$$

and 0-surgery on $\hat{\alpha} \subset S_{+1}$ compresses Σ . Thus, $u(r)$ is nonzero. On the other hand,

$$u(r) = u(p(s)),$$

and the composition

$$(3.10) \quad I^\#(A_0 \# B_0) \xrightarrow{p} I^\#(S_{+1}) \xrightarrow{u} I^\#(A_0 \# B_0, \mu_\alpha \cup \mu_\beta)$$

is identically zero since, as we will show momentarily, the composite cobordism contains a 2-sphere V with self-intersection 0 on which the restriction of the $SO(3)$ -bundle is nontrivial [BS21, Proof of Proposition 3.3], a contradiction.

The sphere V is depicted in Figure 3.6, as the union of an annulus $V_\gamma \subset S_{+1}$ with disks V_α and V_β , where V_α is the core of the 2-handle attachment that induces the map u , and V_β is the co-core of the 2-handle attachment that induces p . The mod 2 class

$$[\mu_\alpha \cup \mu_\beta] \in H_1(A_0 \# B_0; \mathbb{Z}/2\mathbb{Z})$$

is represented by the meridional curve $\mu_{\alpha\beta}$ shown in Figure 3.5. This curve bounds a properly embedded disk D in the cobordism inducing the map u , obtained by pushing the interior of the meridional disk bounded by $\mu_{\alpha\beta}$ in the surgery diagram into the interior of the cobordism. The second Stiefel-Whitney class of the $SO(3)$ -bundle on the composite cobordism is Poincaré dual to D ; see [ABDS20, § 2.3]. The evaluation of this class on V is therefore given by the mod 2 intersection number of V with D . But this is equal to the mod 2 intersection number of V with $\mu_{\alpha\beta}$, as indicated in Figure 3.6, which is 1. \square

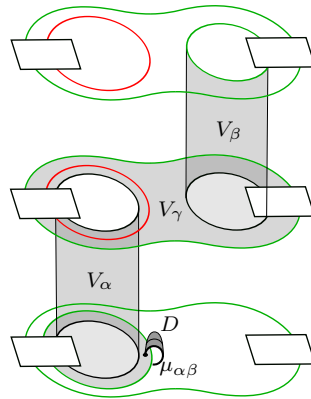

Figure 3.6. The 2-sphere with trivial self-intersection in the cobordism corresponding to the composition in (3.10). It is formed as the union of an annulus V_γ with disks V_α and V_β . It intersects $\mu_{\alpha\beta}$, and thus D , in one point.

Proof of Corollary 1.2. — If Y is not a homology sphere, then there is a nontrivial homomorphism from $\pi_1(Y)$ to $SU(2)$ factoring through $H_1(Y)$. We may thus assume that Y is a homology sphere, in which case it can be expressed as the splice of nontrivial knots $K_1 \subset Y_1$ and $K_2 \subset Y_2$ in homology spheres, in which the complements are glued by a map that identifies meridians with Seifert longitudes. There is a π_1 -surjective map from Y to each Y_i , so if some $\pi_1(Y_i)$ admits a nontrivial $SU(2)$ -representation then so does $\pi_1(Y)$. We may thus assume that

neither $\pi_1(Y_1)$ nor $\pi_1(Y_2)$ admits a nontrivial $SU(2)$ -representation. Then these Y_i are instanton L -spaces, as explained in the introduction, so Theorem 1.1 tells us that Y is not an instanton L -space. But this in turn implies that $\pi_1(Y)$ admits a nontrivial homomorphism to $SU(2)$. \square

Proof of Corollary 1.3. — As in the previous proof, we may assume Y is a homology sphere. We can further assume Y is prime, in which case Y is hyperbolic, Seifert fibered, or toroidal, by geometrization. If Y is hyperbolic then the holonomy representation $\pi_1(Y) \rightarrow PSL(2, \mathbb{C})$ lifts to a nontrivial representation $\pi_1(Y) \rightarrow SL(2, \mathbb{C})$ [CS83, Proposition 3.1.1]. If $Y \not\cong S^3$ is Seifert fibered then $\pi_1(Y)$ admits a nontrivial homomorphism to $SU(2)$, and hence to $SL(2, \mathbb{C})$ [FS90]; see also [BS18, Theorem 5.1]. Finally, if Y is toroidal then $\pi_1(Y)$ admits a nontrivial homomorphism to $SU(2)$, and hence $SL(2, \mathbb{C})$, by Corollary 1.2. \square

4. The framed instanton homology of a longitudinal splice

The goal of this section is to prove Theorem 3.1. We will assume familiarity with sutured instanton homology at the level of [KM10]. All sutured manifolds in this section are assumed to be balanced with nonempty sutures.

Given a sutured manifold $M = (M, \gamma)$ and a positive integer k , let $M(k)$ be the sutured manifold obtained by removing k 3-balls from the interior of M and adding a circle on each of the resulting 2-sphere boundary components to the suture γ . Recall that

$$I^\#(Y) \cong SHI(Y(1))$$

for any closed 3-manifold Y . We start with the preliminary lemma below.

LEMMA 4.1. — *For any two sutured manifolds M and N ,*

$$\dim SHI(M\#N) = \dim SHI(M) \cdot \dim SHI(N(1)).$$

Proof. — Note that $M\#N$ is obtained from $M \sqcup N(1) \cong M \sqcup S^3(1)\#N$ by attaching a contact 1-handle. Since such attachments preserve sutured instanton homology [BS16, § 3.2], we have

$$SHI(M\#N) \cong SHI(M \sqcup N(1)) \cong SHI(M) \otimes SHI(N(1)),$$

proving the lemma. \square

COROLLARY 4.2. — *For any sutured manifold M and positive integer k ,*

$$\dim SHI(M(k)) = 2^k \cdot \dim SHI(M).$$

Proof. — Note that $(S^1 \times S^2)(1)$ can be obtained by attaching a contact 1-handle to $S^3(2)$, so

$$\dim SHI(S^3(2)) = \dim SHI((S^1 \times S^2)(1)) = \dim I^\#(S^1 \times S^2) = 2.$$

Since $M(k) \cong M(k-1)\#S^3(1)$, Lemma 4.1 says that

$$\dim SHI(M(k)) = \dim SHI(M(k-1)) \cdot \dim SHI(S^3(2)) = 2 \cdot \dim SHI(M(k-1)),$$

and the Corollary 4.2 follows by induction. \square

COROLLARY 4.3. — *For any nontrivial knot α in a closed, oriented homology sphere A ,*

$$\dim KHI(A, \alpha, g(\alpha)) \geq 1.$$

Proof. — Let Σ be a minimal genus Seifert surface for α , and let $A(\Sigma)$ be the sutured manifold obtained from A by removing a neighborhood of α and then of Σ , with suture consisting of one curve isotopic to $\partial\Sigma$. Then

$$KHI(A, \alpha, g(\alpha)) \cong SHI(A(\Sigma)).$$

Sutured instanton homology is nonzero for any taut sutured manifold [KM10, Theorem 7.2]. Since Σ has minimal genus, the only way $A(\Sigma)$ can fail to be taut is if it is not prime. In this case, we can write

$$A(\Sigma) = A(\Sigma)' \# Y,$$

where $A(\Sigma)'$ is a taut sutured manifold and Y is a homology sphere. Then

$$A(\Sigma)(1) = A(\Sigma)' \# Y(1),$$

whence Lemma 4.1 and Corollary 4.2 tell us that

$$\begin{aligned} \dim SHI(A(\Sigma)) &= (1/2) \cdot \dim SHI(A(\Sigma)(1)) \\ &= (1/2) \cdot \dim SHI(A(\Sigma)') \cdot \dim SHI(Y(2)) \\ &= \dim SHI(A(\Sigma)') \cdot \dim SHI(Y(1)) = \dim SHI(A(\Sigma)') \cdot \dim I^\#(Y), \end{aligned}$$

which is nonzero since $A(\Sigma)'$ is taut and $\chi(I^\#(Y)) = 1$. □

We will require one more lemma before proving Theorem 3.1.

LEMMA 4.4. — *Let Y be a closed, oriented 3-manifold. Let Σ be a closed, oriented surface in Y of genus at least two, and λ a multicurve in Y which intersects some surface of positive genus disjoint from Σ in an odd number of points. Suppose (Y', λ') is obtained by cutting (Y, λ) open along Σ and regluing by a homeomorphism of Σ which preserves $\Sigma \cap \lambda$. Then*

$$I_*(Y|\Sigma)_\lambda \cong I_*(Y'|\Sigma)_{\lambda'}.$$

Proof. — When $\Sigma \cap \lambda$ consists of an odd number of points, this is simply excision. In general, it suffices to consider the case in which the regluing homeomorphism is a positive Dehn twist along an essential curve $\gamma \subset \Sigma$. In this case, Y' is the result of -1 -surgery on $\gamma \subset Y$. Consider the exact triangle relating the Floer homologies of Y , $Y_{-1}(\gamma) \cong Y'$, and $Y_0(\gamma)$:

$$\cdots \rightarrow I_*(Y)_\lambda \xrightarrow{f} I_*(Y')_{\lambda'} \rightarrow I_*(Y_0(\lambda))_{\lambda' \cup \mu} \rightarrow \cdots,$$

where μ is a meridian of γ . The maps in this triangle respect the eigenspaces of the operators $\mu(\Sigma)$ and $\mu(\text{pt})$. On the other hand, 0 -surgery on γ compresses Σ , which implies that

$$I_*(Y_0(\lambda)|\Sigma)_{\lambda' \cup \mu} = 0.$$

It follows that f restricts to an isomorphism from $I_*(Y|\Sigma)_\lambda$ to $I_*(Y'|\Sigma)_{\lambda'}$. □

This immediately implies Corollary 4.5 below, since

$$I^\#(Y, \lambda|\Sigma) = I_*\left(Y \# T^3 \Big| \Sigma\right)_{\lambda \cup \lambda_T}.$$

COROLLARY 4.5. — *Let Y be a closed, oriented 3-manifold. Let Σ be a closed, oriented surface in Y of genus at least two, and λ a multicurve in Y . Suppose (Y', λ') is obtained by cutting (Y, λ) open along Σ and regluing by a homeomorphism of Σ which preserves $\Sigma \cap \lambda$. Then*

$$I^\#(Y, \lambda|\Sigma) \cong I^\#(Y', \lambda'|\Sigma).$$

Proof of Theorem 3.1. — Let $\alpha \subset A$ and $\beta \subset B$ be as in hypothesis of the theorem. Let S be any splice formed by gluing the complements

$$S = (A - N(\alpha)) \cup (B - N(\beta))$$

via an orientation-reversing homeomorphism of their boundaries which identifies the Seifert longitudes of these knots. Let $\bar{\Sigma}$ be the closed surface in S of genus at least two obtained as the union of minimal genus Seifert surfaces $\Sigma_\alpha \subset A - N(\alpha)$ and $\Sigma_\beta \subset B - N(\beta)$ for α and β . Since A and B are homology spheres,

$$H_1(S; \mathbb{Z}/2\mathbb{Z}) \cong \mathbb{Z}/2\mathbb{Z},$$

generated by the meridian μ of α , say. Then $\lambda = 0$ or μ . We will first show that

$$(4.1) \quad I^\#(S, 0|\Sigma) \cong I^\#(S, \mu|\Sigma).$$

Then we will show by an excision argument that

$$(4.2) \quad \dim I^\#(S, \mu|\Sigma) = 2 \cdot \dim KHI(A, \alpha, g(\alpha)) \cdot \dim KHI(B, \beta, g(\beta)).$$

Theorem 3.1 will then follow immediately from (4.2) together with (2.1) and Corollary 4.3.

Let $A(\Sigma_\alpha)$ and $B(\Sigma_\beta)$ be the standard sutured complements of the Seifert surfaces $\Sigma_\alpha \subset A$ and $\Sigma_\beta \subset B$. Each has vertical boundary an annular neighborhood of the suture,

$$\partial_v A(\Sigma_\alpha) \cong \partial_v B(\Sigma_\beta) \cong (\partial\Sigma_\alpha = \partial\Sigma_\beta) \times [0, 1],$$

while their horizontal boundaries are given by

$$\begin{aligned} \partial_h A(\Sigma_\alpha) &= \Sigma_\alpha \sqcup \Sigma_\alpha \\ \partial_h B(\Sigma_\beta) &= \Sigma_\beta \sqcup \Sigma_\beta. \end{aligned}$$

The manifold obtained by cutting S open along Σ can alternatively be viewed as the result

$$\bar{S} = A(\Sigma_\alpha) \cup B(\Sigma_\beta)$$

of gluing $A(\Sigma_\alpha)$ and $B(\Sigma_\beta)$ along their vertical boundaries. We can view

$$\partial\bar{S} = \Sigma_1 \sqcup \Sigma_0,$$

as the disjoint union of two identical copies of Σ , so that S is obtained from \bar{S} by gluing Σ_1 to Σ_0 by the identity.

There is another convenient way to think about \bar{S} and S . Consider the manifolds

$$\begin{aligned} A' &= A(\Sigma_\alpha) \cup (\Sigma_\beta \times [1/2, 1]) \\ B' &= B(\Sigma_\beta) \cup (\Sigma_\alpha \times [0, 1/2]), \end{aligned}$$

obtained by gluing their constituent pieces by homeomorphisms

$$\begin{aligned} \partial\Sigma_\beta \times [1/2, 1] &\rightarrow \partial_v A(\Sigma_\alpha) \\ \partial\Sigma_\alpha \times [0, 1/2] &\rightarrow \partial_v B(\Sigma_\beta). \end{aligned}$$

The boundaries of A' and B' can each be viewed as consisting of two identical copies of Σ ,

$$\begin{aligned} \partial A' &= \Sigma_1 \sqcup \Sigma_{1/2} \\ \partial B' &= \Sigma_0 \sqcup \Sigma_{1/2}, \end{aligned}$$

so that \bar{S} is obtained by gluing A' to B' according to the identity on $\Sigma_{1/2}$, and S is obtained by additionally gluing Σ_1 to Σ_0 by the identity, as indicated in Figure 4.1.

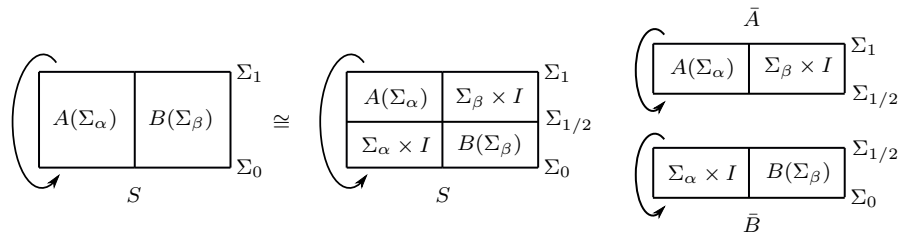

Figure 4.1. Left, S obtained from $A(\Sigma_\alpha) \cup B(\Sigma_\beta)$ via the identification $\Sigma_1 \sim \Sigma_0$. Middle, S obtained from $A' \cup B'$ by identifying $\Sigma_1 \sim \Sigma_0$. Right, $\bar{A} \sqcup \bar{B}$ obtained from $A' \sqcup B'$ via identifications $\Sigma_1 \sim \Sigma_{1/2}$ and $\Sigma_{1/2} \sim \Sigma_0$.

Pick essential curves $c_\alpha \subset \Sigma_\alpha$ and $c_\beta \subset \Sigma_\beta$, and let δ be a curve in Σ_α which intersects c_α transversely in one point. Since A is a homology sphere and δ has linking number zero with α , the curve δ is homologically trivial in $A - N(\alpha)$ and hence in S , so

$$(4.3) \quad I^\#(S, 0|\Sigma) \cong I^\#(S, \delta|\Sigma).$$

Let S' be the manifold obtained by gluing A' to B' by a homeomorphism $\partial A' \rightarrow \partial B'$ sending

$$\begin{aligned} c_\beta \times \{1\} &\mapsto c_\alpha \times \{0\} \\ c_\beta \times \{1/2\} &\mapsto c_\alpha \times \{1/2\}, \end{aligned}$$

so that the cylinders

$$\begin{aligned} c_\beta \times [1/2, 1] &\subset A' \\ c_\alpha \times [0, 1/2] &\subset B' \end{aligned}$$

glue to form a torus $T \subset S'$ which intersects the curve δ in a single point. Note that S' can be obtained by cutting S along $\Sigma_0 \sim \Sigma_1$ and $\Sigma_{1/2}$ and regluing. Therefore,

$$(4.4) \quad I^\#(S, \delta|\Sigma) \cong I^\#(S', \delta|\Sigma),$$

by Corollary 4.5.

Now consider the 3-torus $T^3 = T^2 \times S^1$ containing the curve

$$\lambda = \text{pt} \times S^1 \subset T^3.$$

Let $c \subset T^2$ be an essential curve, and $d \subset T^2 \times \text{pt}$ a curve intersecting $c \times \text{pt}$ transversely in one point. There is a cobordism

$$(4.5) \quad (S', \delta) \sqcup (T^3, d \cup \lambda) \rightarrow (S', \delta \cup \lambda)$$

associated to cutting (S', δ) and $(T^3, d \cup \lambda)$ open along the tori

$$T \subset S'$$

$$c \times S^1 \subset T^3$$

and regluing by a homeomorphism which connects these pieces, as illustrated in Figure 4.2. By excision [KM10, Theorem 7.7] and the computation $I_*(T^3|T^2)_{d \cup \lambda} \cong \mathbb{Q}$ of [KM10, Proposition 7.8], this cobordism induces an isomorphism

$$(4.6) \quad I^\#(S', \delta|\Sigma) \cong I^\#(S', \delta|\Sigma) \otimes I_*(T^3|T^2)_{d \cup \lambda} \rightarrow I^\#(S', \delta \cup \lambda|\Sigma).$$

Since λ intersects Σ in one point, another application of Corollary 4.5 tells us that

$$(4.7) \quad I^\#(S', \delta \cup \lambda|\Sigma) \cong I^\#(S, \delta \cup \lambda|\Sigma) \cong I^\#(S, \delta \cup \mu|\Sigma),$$

where the second isomorphism comes from the fact that λ and μ both represent the generator of $H_1(S; \mathbb{Z}/2\mathbb{Z}) \cong \mathbb{Z}/2\mathbb{Z}$. Finally,

$$(4.8) \quad I^\#(S, \delta \cup \mu|\Sigma) \cong I^\#(S, \mu|\Sigma),$$

since δ is nullhomologous in S . Combining (4.3)-(4.8) proves the isomorphism (4.1).

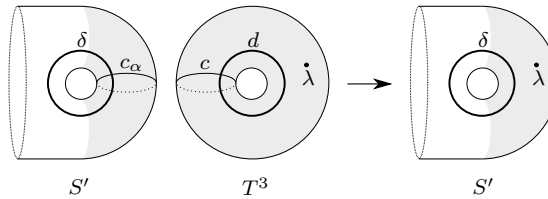

Figure 4.2. A schematic of the cobordism (4.5). The cutting and regluing occurs in the product of the gray region with S^1 . The torus $T \subset S'$ is swept out by c_α , and λ is swept out by the points indicated on these surfaces.

To prove (4.2), we form S by gluing A' to B' as described above. There is a cobordism

$$(S, \mu) \rightarrow (\bar{A}, \mu_A) \sqcup (\bar{B}, \mu_B),$$

associated to cutting S open along $\Sigma_{1/2}$ and $\Sigma_1 \sim \Sigma_0$ and regluing, where

$$\bar{A} = A' / (\Sigma_1 \sim \Sigma_{1/2})$$

$$\bar{B} = B' / (\Sigma_0 \sim \Sigma_{1/2})$$

are the closed 3-manifolds obtained from each of A' and B' by gluing their boundary components together by the identity, as in Figure 4.1, and $\mu_\alpha \subset \bar{A}$ and $\mu_\beta \subset \bar{B}$ intersect $\Sigma \subset \bar{A}$ and $\Sigma \subset \bar{B}$ in one point, respectively. By excision, this cobordism induces an isomorphism

$$I^\#(S, \mu|\Sigma) = I_*(S\#T^3|\Sigma)_{\mu \cup \lambda_T} \rightarrow I_*(\bar{A}\#T^3|\Sigma)_{\mu_\alpha \cup \lambda_T} \otimes I_*(\bar{B}|\Sigma)_{\mu_\beta},$$

but the tensor product on the right is, by definition [KM10, § 7], precisely

$$SHI(A(\Sigma_\alpha)(1)) \otimes SHI(B(\Sigma_\beta)),$$

which, by Corollary 4.2, has dimension

$$\begin{aligned} & 2 \cdot \dim SHI(A(\Sigma_\alpha)) \cdot \dim SHI(B(\Sigma_\beta)) \\ & = 2 \cdot \dim KHI(A, \alpha, g(\alpha)) \cdot \dim KHI(B, \beta, g(\beta)), \end{aligned}$$

as desired. \square

Remark 4.6. — One can prove the Heegaard Floer homology analogue of Theorem 3.1 by a couple of different arguments. One can, for instance, simply mimic the argument above, using Lekili’s excision result for Heegaard Floer homology in [Lek09].

BIBLIOGRAPHY

- [ABDS20] Antonio Alfieri, John A. Baldwin, Irving Dai, and Steven Sivek, *Instanton Floer homology of almost-rational plumbings*, <https://arxiv.org/abs/2010.03800>, 2020. \uparrow 1217, 1225
- [BS16] John A. Baldwin and Steven Sivek, *Instanton Floer homology and contact structures*, *Sel. Math., New Ser.* **22** (2016), no. 2, 939–978. \uparrow 1226
- [BS18] ———, *Stein fillings and $SU(2)$ representations*, *Geom. Topol.* **22** (2018), no. 7, 4307–4380. \uparrow 1214, 1215, 1226
- [BS21] ———, *Framed instanton homology and concordance*, *J. Topol.* **14** (2021), no. 4, 1113–1175. \uparrow 1217, 1218, 1225
- [BS22a] ———, *Framed instanton homology and concordance, II*, <https://arxiv.org/abs/2206.11531>, 2022. \uparrow 1218
- [BS22b] ———, *Khovanov homology detects the trefoils*, *Duke Math. J.* **171** (2022), no. 4, 885–956. \uparrow 1217
- [CS83] Marc Culler and Peter B. Shalen, *Varieties of group representations and splittings of 3-manifolds*, *Ann. Math.* **117** (1983), no. 1, 109–146. \uparrow 1226
- [Eft15] Eaman Eftekhary, *Floer homology and splicing knot complements*, *Algebr. Geom. Topol.* **15** (2015), no. 6, 3155–3213. \uparrow 1214
- [Eft20] ———, *Correction to the article Floer homology and splicing knot complements*, *Algebr. Geom. Topol.* **20** (2020), no. 6, 3205–3218. \uparrow 1214
- [Flo90] Andreas Floer, *Instanton homology, surgery, and knots*, *Geometry of low-dimensional manifolds, 1* (Durham, 1989), London Mathematical Society Lecture Note Series, vol. 150, Cambridge University Press, 1990, pp. 97–114. \uparrow 1217
- [FS90] Ronald Fintushel and Ronald J. Stern, *Instanton homology of Seifert fibred homology three spheres*, *Proc. Lond. Math. Soc.* **61** (1990), no. 1, 109–137. \uparrow 1226
- [HL16] Matthew Hedden and Adam Simon Levine, *Splicing knot complements and bordered Floer homology*, *J. Reine Angew. Math.* **720** (2016), 129–154. \uparrow 1214
- [HRW17] Jonathan Hanselman, Jacob Rasmussen, and Liam Watson, *Bordered Floer homology for manifolds with torus boundary via immersed curves*, <https://arxiv.org/abs/1604.03466>, 2017. \uparrow 1214, 1215
- [Kirby97] Rob Kirby, *Problems in low-dimensional topology*, *Geometric topology* (Athens, GA, 1993) (Rob Kirby and William H. Kazez, eds.), AMS/IP Studies in Advanced Mathematics, vol. 2, American Mathematical Society, 1997, pp. 35–473. \uparrow 1214

- [KLT21] Çağrı Karakurt, Tye Lidman, and Eamonn Tweedy, *Heegaard Floer homology and splicing homology spheres*, Math. Res. Lett. **28** (2021), no. 1, 93–106. ↑1219
- [KM04] Peter B. Kronheimer and Tomasz S. Mrowka, *Witten’s conjecture and property P*, Geom. Topol. **8** (2004), 295–310. ↑1214
- [KM10] ———, *Knots, sutures, and excision*, J. Differ. Geom. **84** (2010), no. 2, 301–364. ↑1214, 1215, 1216, 1218, 1226, 1227, 1230, 1231
- [KM11a] ———, *Khovanov homology is an unknot-detector*, Publ. Math., Inst. Hautes Étud. Sci. (2011), no. 113, 97–208. ↑1214
- [KM11b] ———, *Knot homology groups from instantons*, J. Topol. **4** (2011), no. 4, 835–918. ↑1214
- [Lek09] Yankı Lekili, *Broken Lefschetz fibrations, Lagrangian matching invariants and Ozsváth–Szabó invariants*, Ph.D. thesis, Massachusetts Institute of Technology, USA, 2009. ↑1231
- [LPCZ21] Tye Lidman, Juanita Pinzón-Cañedo, and Raphael Zentner, *Toroidal homology spheres and $SU(2)$ -representations*, <https://arxiv.org/abs/2101.02621>, 2021. ↑1214, 1215, 1216
- [Sav02] Nikolai Saveliev, *Invariants for homology 3-spheres*, Encyclopaedia of Mathematical Sciences, vol. 140, Springer, 2002, Low-Dimensional Topology, I. ↑1219
- [Sca15] Christopher W. Scaduto, *Instantons and odd Khovanov homology*, J. Topol. **8** (2015), no. 3, 744–810. ↑1214, 1217, 1221
- [SZ22] Steven Sivek and Raphael Zentner, *A menagerie of $SU(2)$ -cyclic 3-manifolds*, Int. Math. Res. Not. **2022** (2022), no. 11, 8038–8085. ↑1216
- [Zen18] Raphael Zentner, *Integer homology 3-spheres admit irreducible representations in $SL(2, \mathbb{C})$* , Duke Math. J. **167** (2018), no. 9, 1643–1712. ↑1214, 1215

Manuscript received on 2nd April 2021,
revised on 12th April 2022,
accepted on 23rd April 2022.

Recommended by Editors X. Caruso and V. Colin.
Published under license CC BY 4.0.



eISSN: 2644–9463

This journal is a member of Centre Mersenne.



John A. BALDWIN
Department of Mathematics,
Maloney Hall, Fifth Floor,
Boston College, Chestnut Hill,
MA, 02467-3806 (USA)
john.baldwin@bc.edu

Steven SIVEK
Max Planck Institute for Mathematics
Vivatsgasse 7
53111 Bonn (Germany)
Department of Mathematics,
Imperial College London,

180 Queen's Gate,
London SW7 2AZ (United Kingdom)
ssivek@mpim-bonn.mpg.de